

MEDIUM RESOLUTION ACCELEROMETER (4-20 mA)

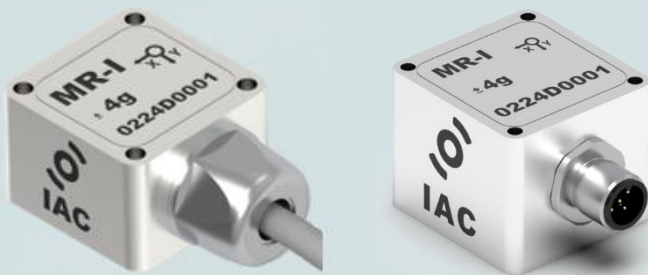

PROPERTIES

- 2 axes
- Suited for direct connection to standard control and measurement equipment
- Embedded 4..20mA signal conditioning
- Galvanically Isolated
- Protected against false polarization
- Compact and rugged design
- Protection grade IP67

BLOCK DIAGRAM

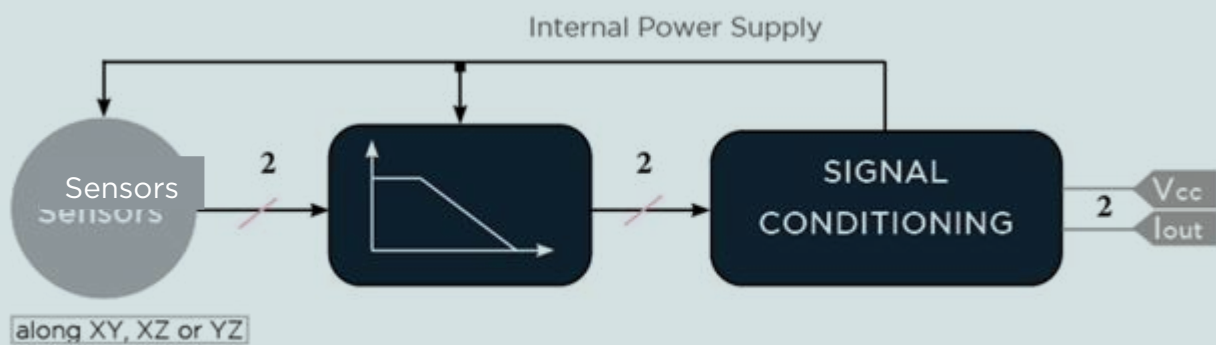

DIMENSIONS - Cable Gland Model

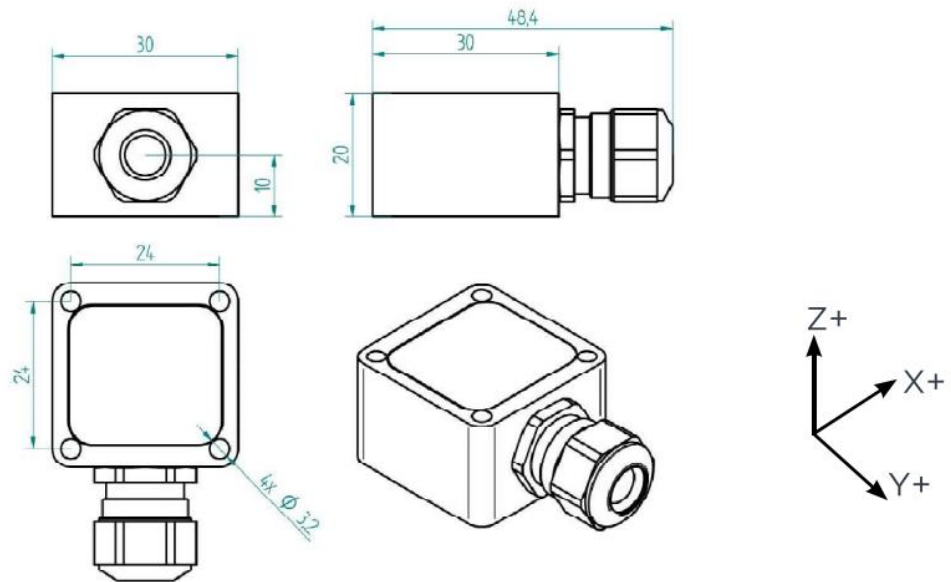

DIMENSIONS - M12 Connector Model

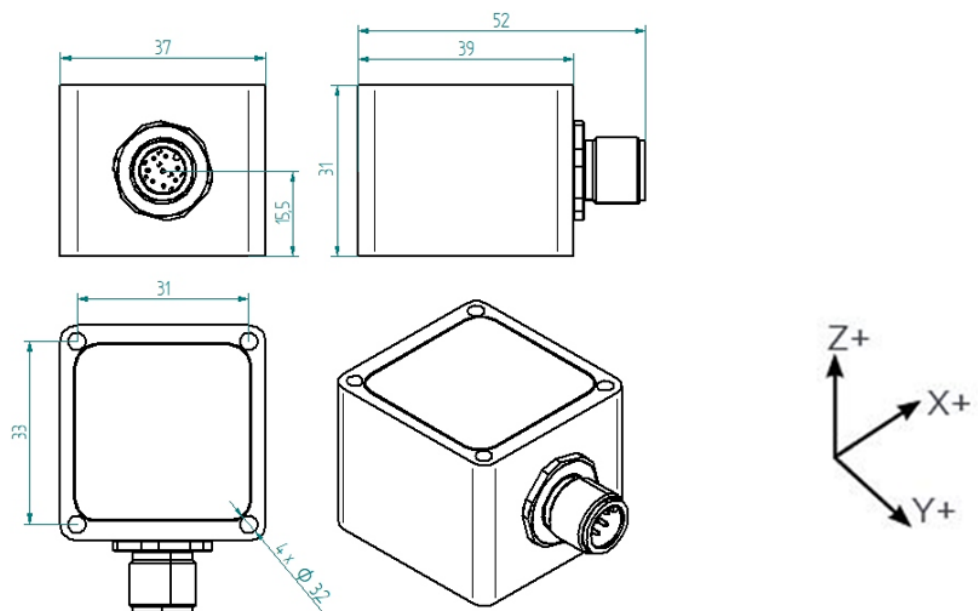

MOUNTING ACCESSORIES

See " IAC - Accelerometer Accessories data sheet "

SPECIFICATIONS - All Models

OUTPUT/CHANNEL	Output Range	4-20mA
	Supply Voltage	12-30 VDC
	Measuring Range	± 2g or ± 4g or ± 8g
	Sensitivity	3.53mA/g (±2g), 1.76mA/g (±4g), 0.88mA/g (±8g)
	Lower frequency limit	0 Hz (DC)
	Upper 3 dB frequency limit	100, 250, 500 or 1000 Hz (1st and 2nd order)
	Non-linearity	± 0.5 % F.S. (±2g, ±4g), ± 1.2 % F.S. (±8g)
	Residual noise (Typical)	24 µg/√Hz (±2g), 27 µg/√Hz (±4g), 30 µg/√Hz (±8g)
	Transverse Sensitivity	< 5%
	Destruction limit	± 5000g
ENVIRONMENTAL CHARACTERISTICS	Temperature Range	Operating -40 to 85°C / -40 to 185°F
	Temperature coefficient of sensitivity	± 0.02 % /°C
	Temperature drift of zero point	± 0.1 mg/°C (±2g, ±4g), ± 0.15 mg/°C (±8g)
	Protection grade	IP67
MECHANICAL DATA	Resonance frequency	2.4kHz
	Case Material	Stainless Steel or Aluminium
	Mounting	3.2 mm diameter holes (4x)
	Weight Without Cable (g)	(¹) CG/101, CO/218 - (²) CG/60, CO/132

⁽¹⁾ Stainless Steel Casing AISI316 Grade (e.g. for offshore/marine environment)

⁽²⁾ Aluminum (MIL-A-8625 Type II coating)

All characteristics are subject to modification if product evolution

ELECTRICAL CONNECTIONS - Cable Gland Model

Signal XY sensing	Signal XZ sensing	Signal YZ sensing	4 x 0,25 ²
Sensor supply + input	Sensor supply + input	Sensor supply + input	Brown
Sensor supply - input	Sensor supply - input	Sensor supply - input	White
X Axis Out	X Axis Out	Y Axis Out	Yellow
Y Axis Out	Z Axis Out	Z Axis Out	Green

ELECTRICAL CONNECTIONS - M12 Connector Model

I 02		1	OUT 1	4-20mA current output
		2	OUT 2	4-20mA current output
		3	NC	-
		4	+24VDC	Sensor supply + input
		5	0VDC	Sensor supply - input

Selected Axes :

X	OUT 1	X	OUT 1	Y	OUT 1
Y	OUT 2	Z	OUT 2	Z	OUT 2

ELECTRICAL CONNECTIONS

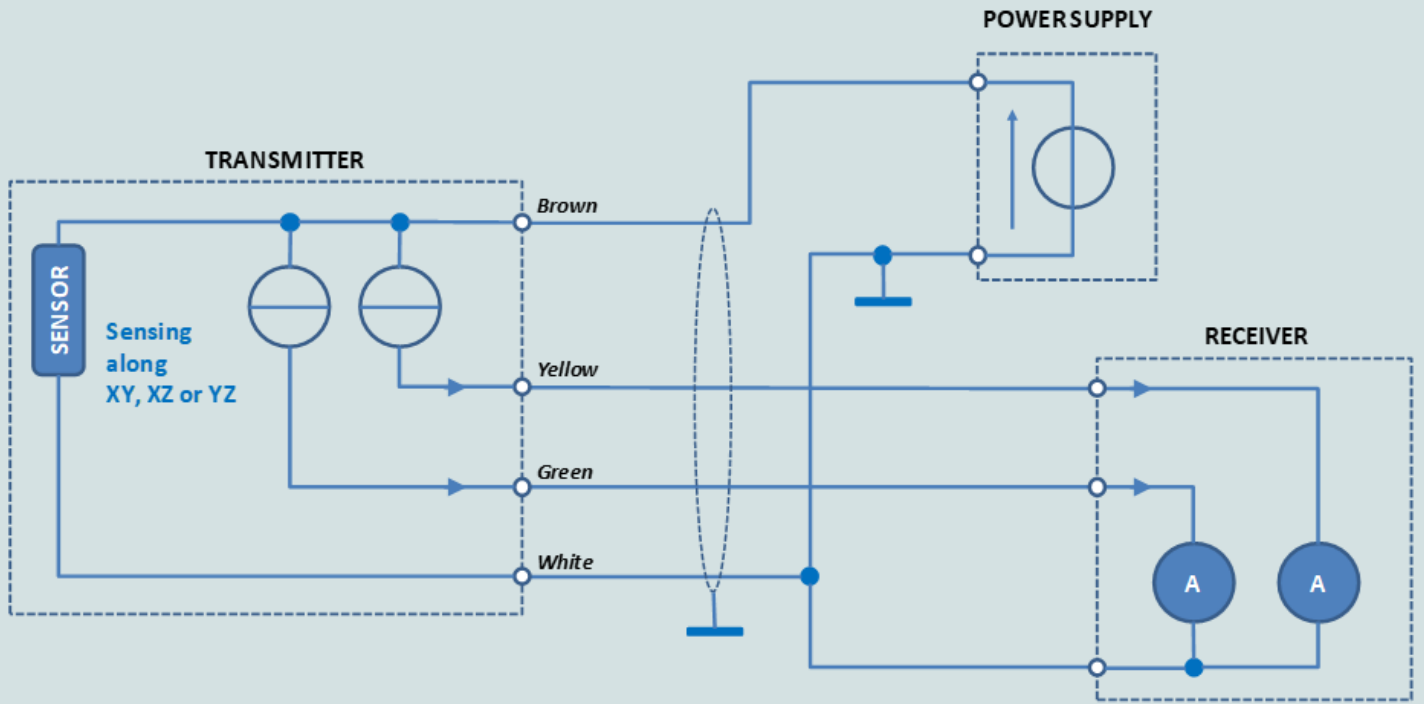

ORDERING INFORMATION

IAC - MR	I	02	AA	XX	XX	Xg	XXXXHz	X	XX.X m	
Sensing Axis		Cable Connection		Casing		Range	Low Pass Filter Frequencies		Low Pass Filter Orders	Cable Length
XY	CG	Cable Gland	AL	Aluminium	± 2g	0100	100Hz	1	1st order	Value in meter
XZ	CO	M12	SS	Stainless Steel	± 4g	0250	250Hz	2	2nd order	
YZ					± 8g	0500	500Hz			
							1000	1000Hz		