

## HIGH RESOLUTION ACCELEROMETER (4-20mA)

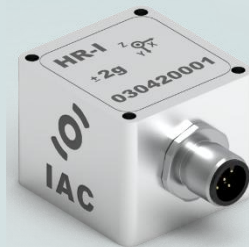
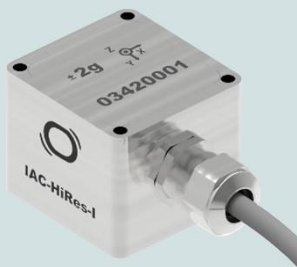

### PROPERTIES

- 3-axes, low noise, high resolution
- Suited for direct connection to standard control and measurement equipment, e.g. PLCs or panel meters
- Embedded 4-20mA signal conditioning
- Galvanically isolated
- Protected against reverse polarization
- Compact and rugged design
- Protection grade IP 67

### BLOCK DIAGRAM

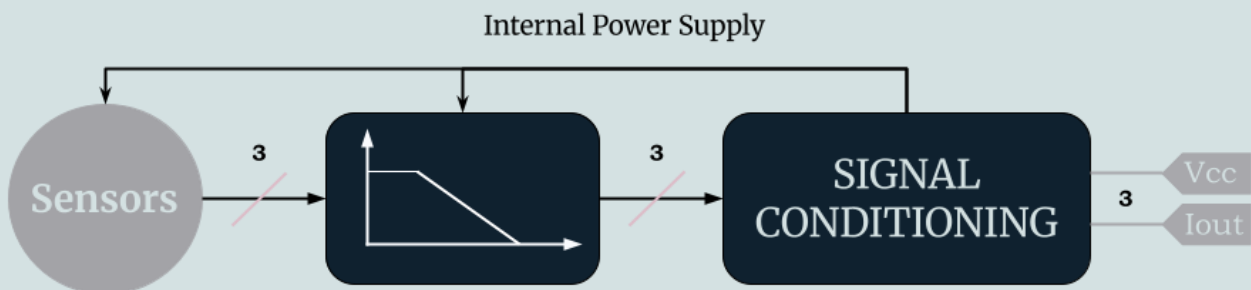

## DIMENSIONS – Cable Gland Model

---

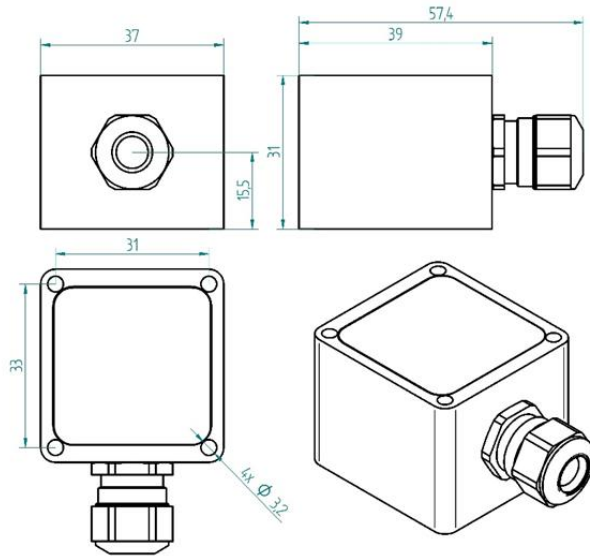

### NOTE

When mounted with sensing axis vertical all units will indicate 1g offset due to gravity

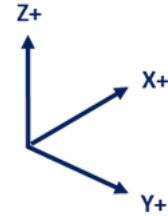

## DIMENSIONS – M12 Connector Model

---

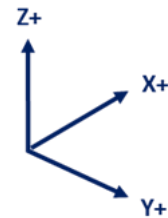
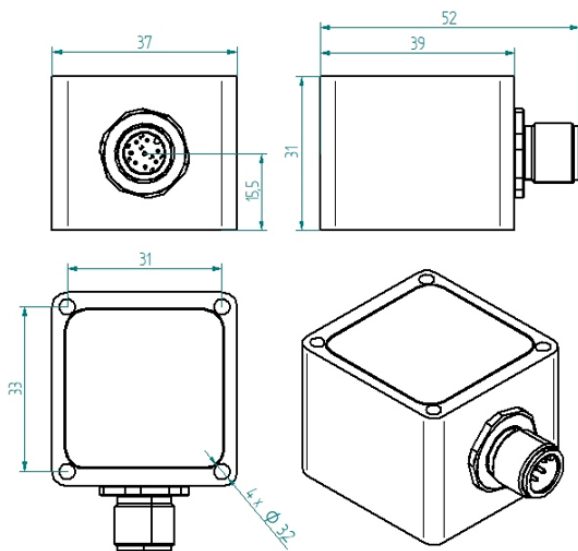

## MOUNTING ACCESSORIES

---

See "IAC – Accelerometer Accessories data sheet"

## SPECIFICATIONS – All Models

OUTPUT / CHANNEL	Output Range	4-20mA
	Supply Voltage	10–30 VDC
	Lower frequency limit	0 Hz (DC)
	Non-linearity	± 0.5 % F.S.
	Sensitivity Error	0.5 % typ. – 1 % max.
	Transverse Sensitivity	2 % typ. – 3 % max.
	Offset	0.2 % F.S. typ. – 0.5 % F.S. max
	Destruction limit <sup>(1)</sup>	± 2000g (±2g / ±5g variants) ; ± 5000g (other variants)
ENVIRONMENTAL CHARACTERISTICS	Temperature Range	Operating -40 to 85°C / -40 to 185°F
	Temperature coefficient of sensitivity	± 0.03 %/°C
	Temperature drift of zero point	± 0.02 % F.S./°C
	Protection grade	IP67
MECHANICAL DATA	Weight Without Cable (g)	<sup>(2)</sup> CG/203, CO/223 - <sup>(3)</sup> CG/117, CO/137
	Case Material	Stainless Steel or Aluminium
	Mounting	3.2 mm diameter holes (4x)

<sup>(1)</sup> Handle the component with caution: dropping the accelerometer on a hard surface can generate several thousand g of acceleration, potentially exceeding absolute maximum limits and damaging the product.

<sup>(2)</sup> Stainless Steel Casing Grade (e.g. for offshore/marine environment)

<sup>(3)</sup> Aluminium (MIL-A-8625 Type II coating)

## PERFORMANCES – By Model

Range - g	Sensitivity - $\mu\text{A/g}$	Freq. Response (-3dB) - Hz	Noise - $\mu\text{g}/\sqrt{\text{Hz}}$ (Typical)
± 2	4000	0 – 400	11
± 5	1600	0 – 600	13
± 10	800	0 – 1000	19
± 25	320	0 – 1500	26
± 50	160	0 – 2000	50
± 100	80	0 – 2500	100
± 200	40	0 – 3000	200
± 400	20	0 – 4000	400

## ELECTRICAL CONNECTIONS – Cable Gland Model

Signal X sensing	Signal Y sensing	Signal Z sensing	5 x 0,25 <sup>2</sup>
Sensor supply + input	Sensor supply + input	Sensor supply + input	Brown
Sensor supply – input	Sensor supply – input	Sensor supply – input	White
X Axis Out			Yellow
	Y Axis Out		Grey
		Z Axis Out	Green

## ELECTRICAL CONNECTIONS – M12 Connector Model

I 03		1	OUT X	4-20mA current output
		2	OUT Y	4-20mA current output
		3	OUT Z	4-20mA current output
		4	+24 VDC	Sensor supply + input
		5	0 VDC	Sensor supply – input

## ELECTRICAL CONNECTIONS

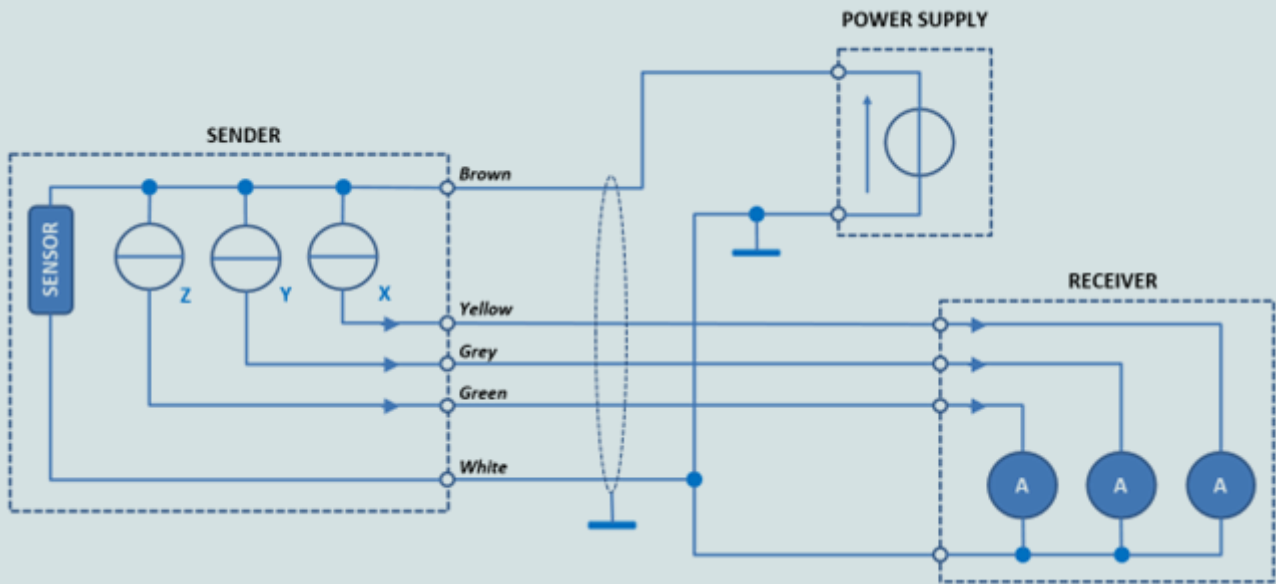

## ORDERING INFORMATION

IAC - HiRes - I - 03 - XX - XX - Xg - XXXXHz - X - XX.X m

Cable Connection		Casing		Range	Low Pass Filter Frequencies		Low Pass Filter Orders		Cable Length	
CG	Cable Gland	AL	Aluminium		± 2g	0100	100Hz	1	1st order	Value in meter
CO	M12	SS	Stainless Steel		± 5g	0250	250Hz	2	2nd order	
					± 10g	0500	500Hz			
					± 25g	1000	1000Hz			
					± 50g					
					± 100g					
					± 200g					
				± 400g						

Specifications subject to change without notice. – Last updated: April 2026