

HIGH RESOLUTION ACCELEROMETER (+/- 4V)

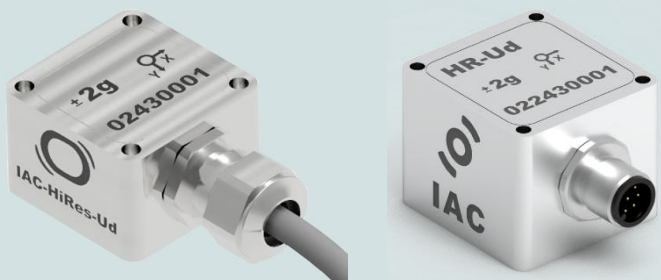

PROPERTIES

- 2-axis, low noise accelerometer
- Amplified +/- 4V differential output
- Suited for direct connection to standard control and measurement equipment, e.g. PLCs or panel meters
- Embedded signal conditioning
- Compact and rugged design
- Protection grade IP 67

BLOCK DIAGRAM

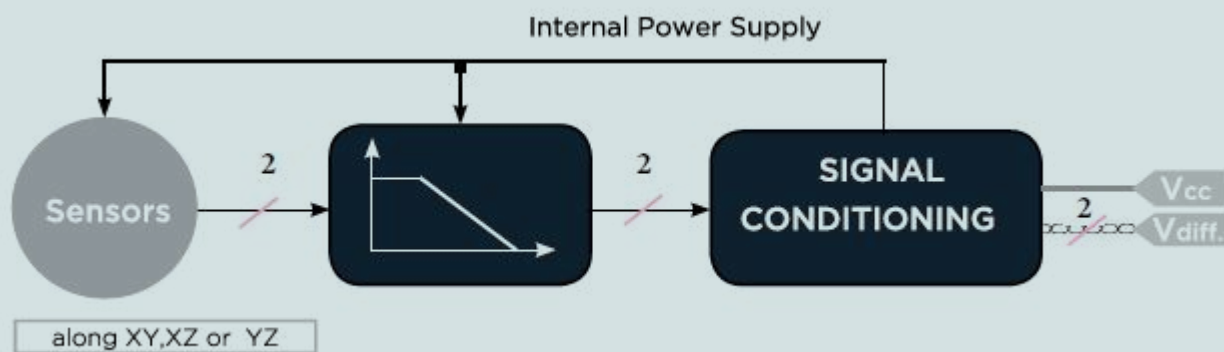

DIMENSIONS – Cable Gland Model

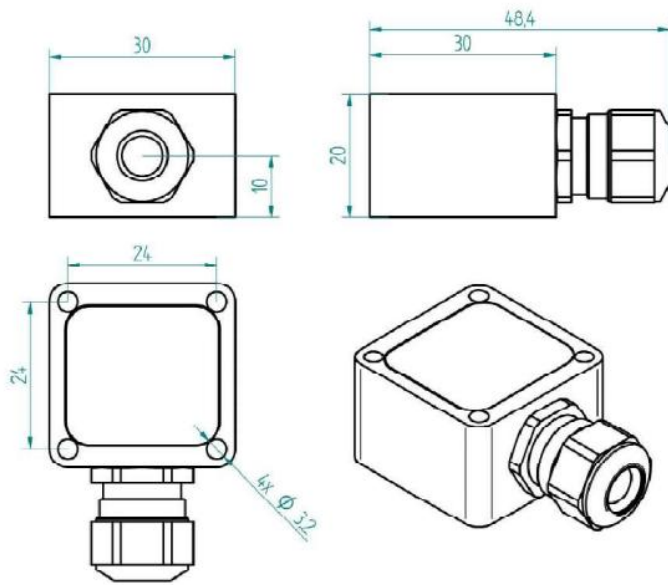

NOTE

When mounted with sensing axis vertical all units will indicate 1g offset due to gravity

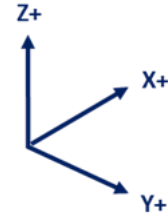

DIMENSIONS – M12 Connector Model

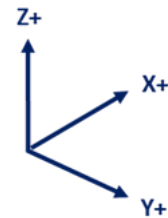
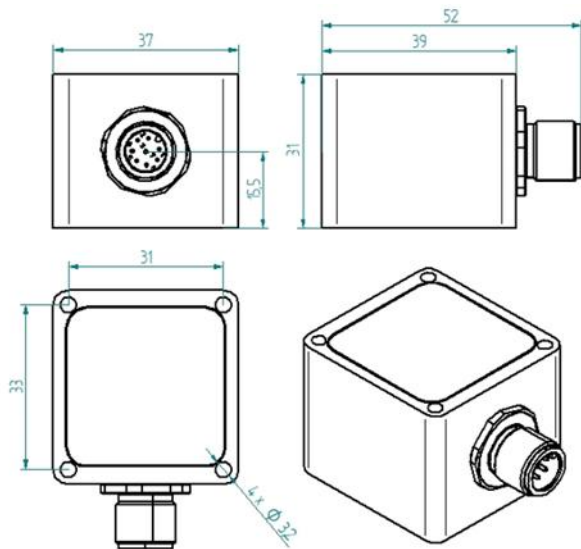

MOUNTING ACCESSORIES

See "IAC – Accelerometer Accessories data sheet"

SPECIFICATIONS – All Models

OUTPUT / CHANNEL	Output Range	± 4V
	Supply Voltage	10–30 VDC
	Lower frequency limit	0 Hz (DC)
	Non-linearity	± 0.5 % F.S.
	Sensitivity Error	0.5 % typ. – 1 % max.
	Transverse Sensitivity	2 % typ. – 3 % max.
	Offset	0.2 % F.S. typ. – 0.5 % F.S. max
	Destruction limit ⁽¹⁾	± 2000g (±2g / ±5g variants) ; ± 5000g (other variants)
ENVIRONMENTAL CHARACTERISTICS	Temperature Range	Operating -40 to 85°C / -40 to 185°F
	Temperature coefficient of sensitivity	± 0.03 %/°C
	Temperature drift of zero point	± 0.02 % F.S./°C
	Protection grade	IP67
MECHANICAL DATA	Weight Without Cable (g)	⁽²⁾ CG/101, CO/237 - ⁽³⁾ CG/60, CO/151
	Case Material	Stainless Steel or Aluminium
	Mounting	3.2 mm diameter holes (4×)

⁽¹⁾ Handle the component with caution: dropping the accelerometer on a hard surface can generate several thousand g of acceleration, potentially exceeding absolute maximum limits and damaging the product.

⁽²⁾ Stainless Steel Casing Grade (e.g. for offshore/marine environment)

⁽³⁾ Aluminium (MIL-A-8625 Type II coating)

PERFORMANCES – By Model

Range - g	Sensitivity - mV/g	Freq. Response (-3dB) - Hz	Noise - µg/√Hz (Typical)
± 2	2000	0 – 400	10
± 5	800	0 – 600	12
± 10	320	0 – 1000	18
± 25	160	0 – 1500	25
± 50	80	0 – 2000	50
± 100	40	0 – 2500	100
± 200	20	0 – 3000	200
± 400	10	0 – 4000	400

ELECTRICAL CONNECTIONS – Cable Gland Model

Signal XY sensing	Signal XZ sensing	Signal YZ sensing	3 x 2 x 0,25 ²
Sensor supply + input	Sensor supply + input	Sensor supply + input	Brown
Sensor supply – input	Sensor supply – input	Sensor supply – input	White
X Axis + Out	X Axis + Out	Y Axis + Out	Yellow
X Axis - Out	X Axis - Out	Y Axis - Out	Green
Y Axis + Out	Z Axis + Out	Z Axis + Out	Pink
Y Axis - Out	Z Axis - Out	Z Axis - Out	Grey

ELECTRICAL CONNECTIONS – M12 Connector Model

Ud 02		1	+24VDC	Sensor supply + input
		2	NC	-
		3	NC	-
		4	OUT 2 -	- Voltage differential output
		5	OUT 2 +	+ Voltage differential output
		6	OUT 1 -	- Voltage differential output
		7	OUT 1 +	+ Voltage differential output
		8	0VDC	Sensor supply - input

Selected Axes:

X	OUT 1	X	OUT 1	Y	OUT 1
Y	OUT 2	Z	OUT 2	Z	OUT 2

ELECTRICAL CONNECTIONS

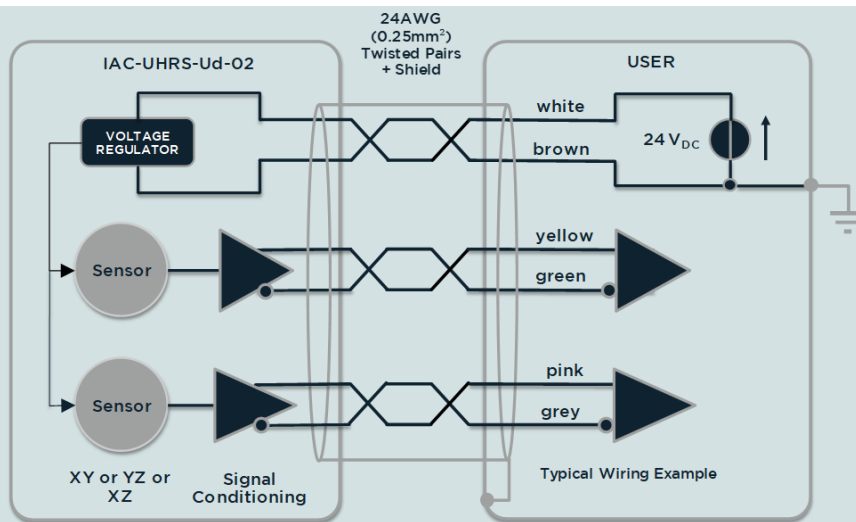

ORDERING INFORMATION

IAC - HiRes - Ud - 02 - AA - XX - XX - Xg - XX.X m

Sensing Axis	Cable Connection		Casing		Range	Cable Length
XY	CG	Cable Gland	AL	Aluminium	± 2g	Value in meter
XZ	CO	M12	SS	Stainless Steel	± 5g	
YZ					± 10g	
					± 25g	
					± 50g	
					± 100g	
					± 200g	
					± 400g	

Specifications subject to change without notice. – Last updated: April 2026