

ULTRA HIGH RESOLUTION ACCELEROMETER (4-20mA)

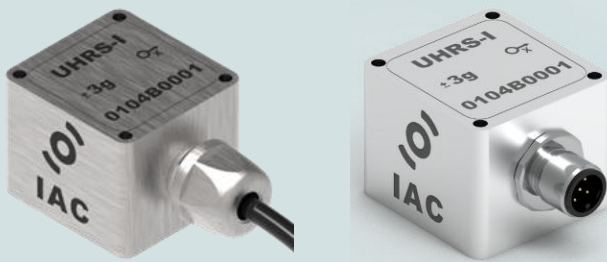

PROPERTIES

- 1-axis, very low noise, ultra-high resolution
- Suited for direct connection to standard control and measurement equipment, e.g. PLCs or panel meters
- Embedded 4-20mA signal conditioning
- Galvanically isolated
- Protected against reverse polarization
- Compact and rugged design
- Protection grade IP 67

BLOCK DIAGRAM

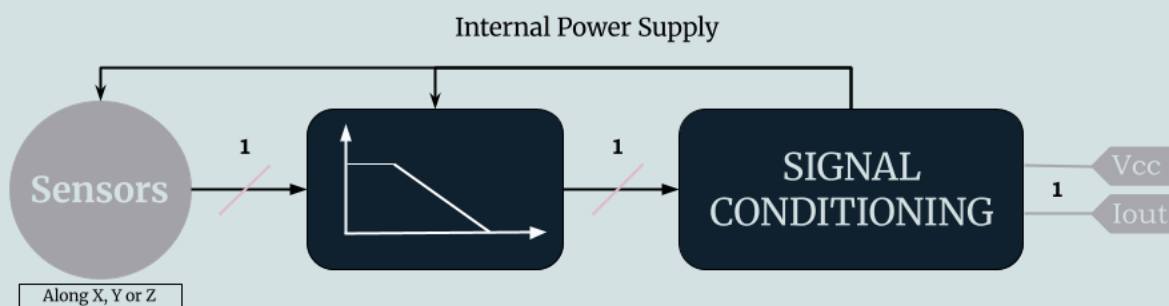

DIMENSIONS – Cable Gland Model

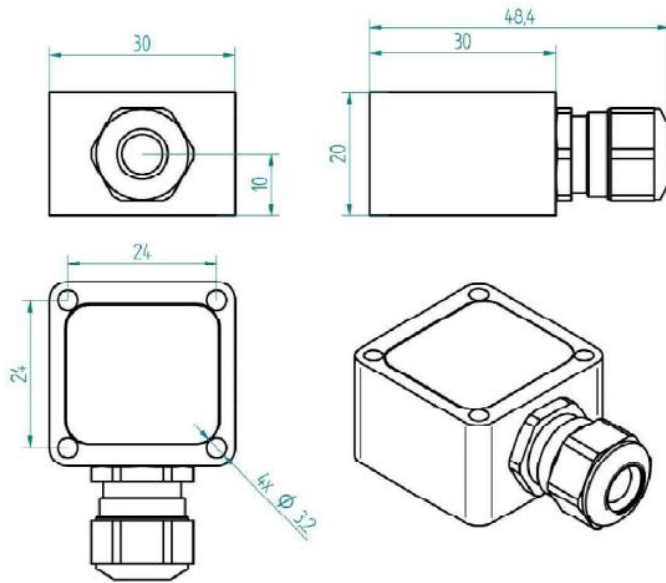

NOTE

When mounted with sensing axis vertical all units will indicate 1g offset due to gravity

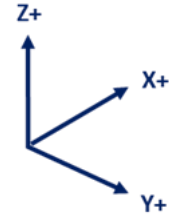

DIMENSIONS – M12 Connector Model

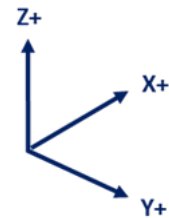
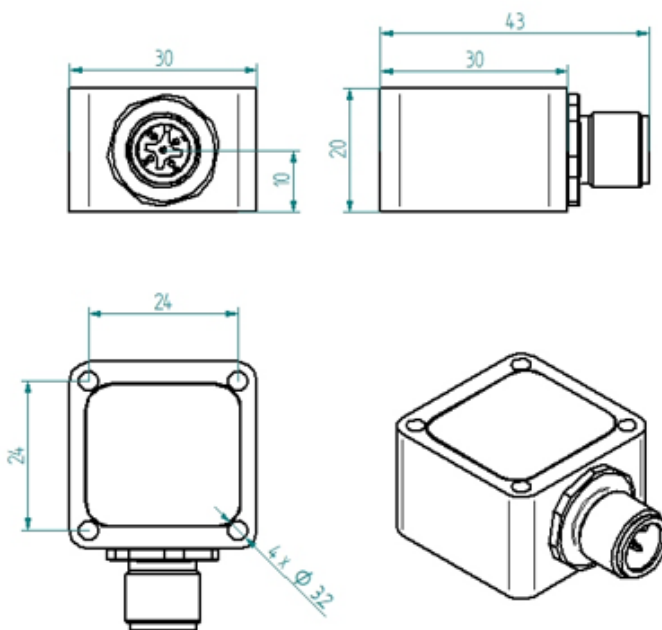

MOUNTING ACCESSORIES

See "IAC – Accelerometer Accessories data sheet"

SPECIFICATIONS – All Models

OUTPUT / CHANNEL	Output Range	4-20mA
	Supply Voltage	10–30 VDC
	Lower frequency limit	0 Hz (DC)
	Non-linearity	± 0.5 % typ. - 1.5% max.
	Sensitivity Error	2 %
	Transverse Sensitivity	2 % typ. – 3 % max.
	Offset	± 20 mg
	Destruction limit ⁽¹⁾	± 1000g
ENVIRONMENTAL CHARACTERISTICS	Temperature Range	Operating -40 to 85°C / -40 to 185°F
	Temperature coefficient of sensitivity	150 ppm/°C
	Temperature drift of zero point	± 0.5 mg/°C
	Protection grade	IP67
MECHANICAL DATA	Weight Without Cable (g)	⁽²⁾ CG/97, CO/213 - ⁽³⁾ CG/57, CO/127
	Case Material	Stainless Steel or Aluminium
	Mounting	3.2 mm diameter holes (4x)

⁽¹⁾ Handle the component with caution: dropping the accelerometer on a hard surface can generate several thousand g of acceleration, potentially exceeding absolute maximum limits and damaging the product.

⁽²⁾ Stainless Steel Casing Grade (e.g. for offshore/marine environment)

⁽³⁾ Aluminium (MIL-A-8625 Type II coating)

PERFORMANCES – By Model

Range - g	Sensitivity - mA/g	Freq. Response (-3dB) - Hz	Noise - µg/√Hz (Typical)
± 3	2.67	0 – 500	2.0
± 5	1.60	0 – 650	2.5

ELECTRICAL CONNECTIONS – Cable Gland Model

Signal X sensing	Signal Y sensing	Signal Z sensing	3 x 0,25 ²
Sensor supply + input	Sensor supply + input	Sensor supply + input	Brown
Sensor supply – input	Sensor supply – input	Sensor supply – input	White
X Axis Out			Green
	Y Axis Out		Green
		Z Axis Out	Green

ELECTRICAL CONNECTIONS – M12 Connector Model

I 01		1	OUT	4-20mA current output
		2	NC	-
		3	NC	-
		4	+24 VDC	Sensor supply + input
		5	0 VDC	Sensor supply – input

ELECTRICAL CONNECTIONS

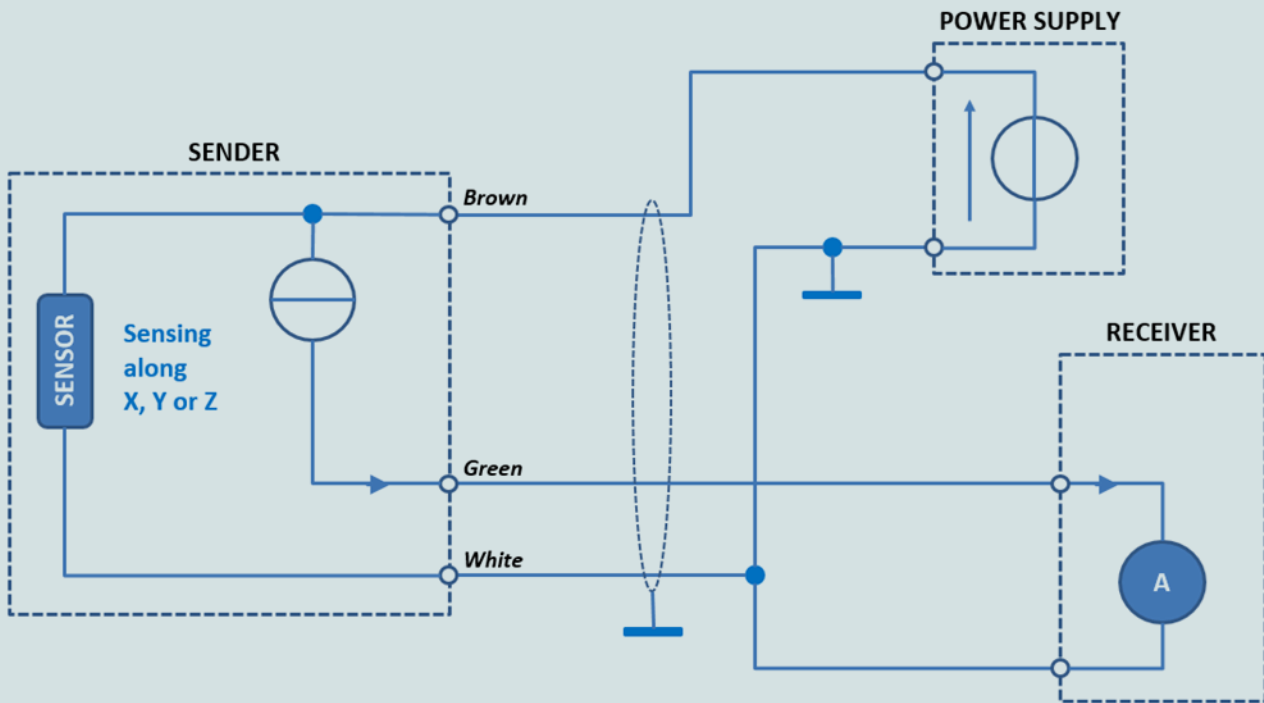

ORDERING INFORMATION

IAC - UHRS	-	I	-	01	-	A	-	XX	-	XX	-	Xg	-	XXXXHz	-	X	-	XX.X m
Sensing Axis		Cable Connection			Casing			Range		Low Pass Filter Frequencies			Low Pass Filter Orders		Cable Length			
X	CG	Cable Gland		AL	Aluminium		± 3g		0	100	100Hz		1	1st order		Value in meter		
Y	CO	M12		SS	Stainless Steel		± 5g		0	250	250Hz		2	2nd order				
Z									0	500	500Hz							

Specifications subject to change without notice. – Last updated: April 2026