

## HIGH RESOLUTION ACCELEROMETER (+/- 2.7V)

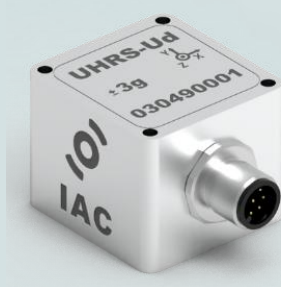
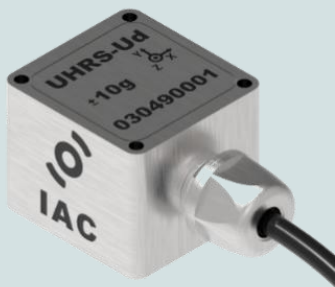

### PROPERTIES

- 3-axis, very low noise accelerometer
- Amplified +/- 4V differential output
- Suited for direct connection to standard control and measurement equipment, e.g. PLCs or panel meters
- Embedded signal conditioning
- Compact and rugged design
- Protection grade IP 67

### BLOCK DIAGRAM

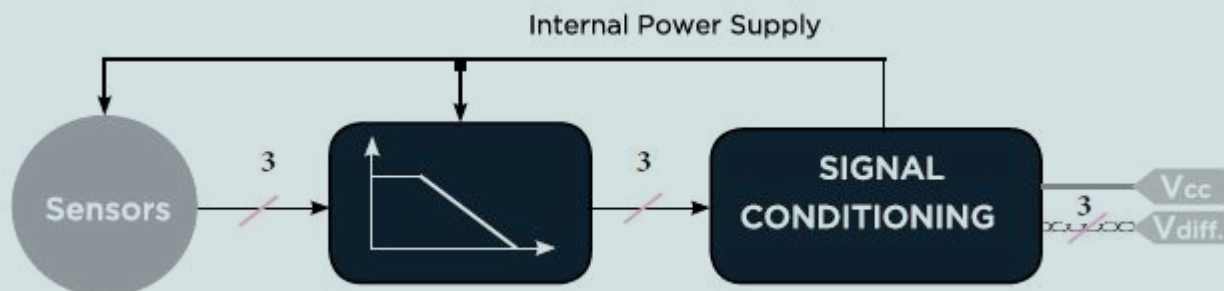

## DIMENSIONS – Cable Gland Model

---

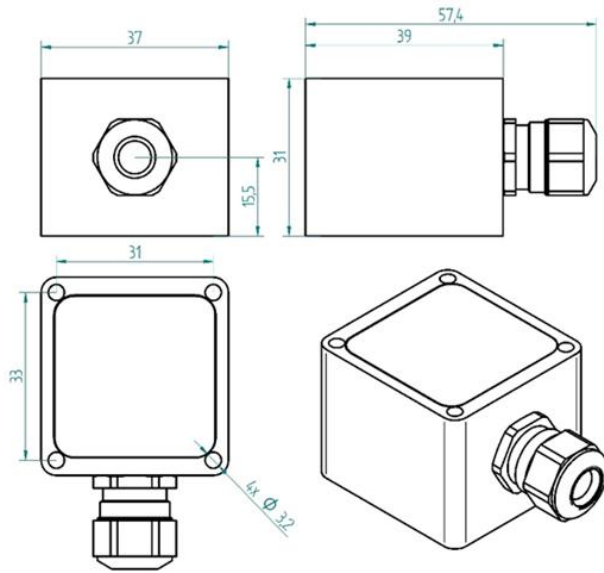

### NOTE

When mounted with sensing axis vertical all units will indicate 1g offset due to gravity

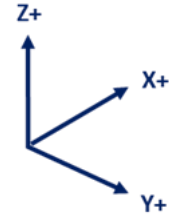

## DIMENSIONS – M12 Connector Model

---

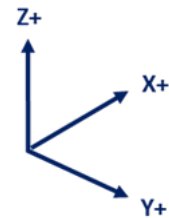
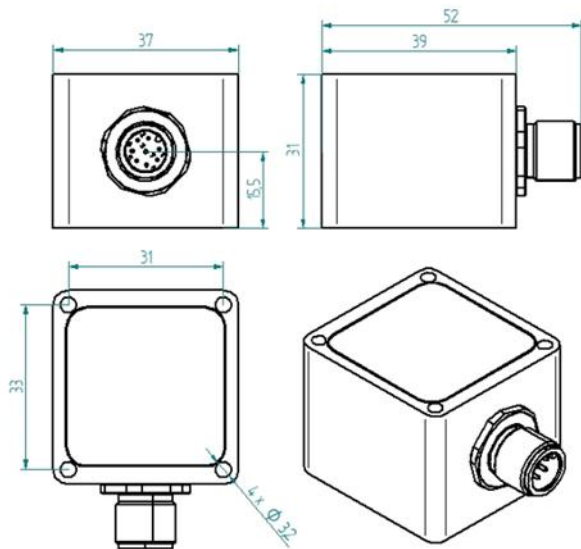

## MOUNTING ACCESSORIES

---

See "IAC – Accelerometer Accessories data sheet"

## SPECIFICATIONS – All Models

OUTPUT / CHANNEL	Output Range	± 2.7V
	Supply Voltage	10-30 VDC
	Lower frequency limit	0 Hz (DC)
	Non-linearity	± 0.5 % typ. - 1.5% max.
	Sensitivity Error	2%
	Transverse Sensitivity	2 % typ. - 3 % max.
	Offset	± 20 mg
	Destruction limit <sup>(1)</sup>	± 1000g
ENVIRONMENTAL CHARACTERISTICS	Temperature Range	Operating -40 to 85°C / -40 to 185°F
	Temperature coefficient of sensitivity	150 ppm/°C
	Temperature drift of zero point	± 0.5 mg/°C
	Protection grade	IP67
MECHANICAL DATA	Weight Without Cable (g)	<sup>(2)</sup> CG/203, CO/242 - <sup>(3)</sup> CG/117, CO/156
	Case Material	Stainless Steel or Aluminium
	Mounting	3.2 mm diameter holes (4x)

<sup>(1)</sup> Handle the component with caution: dropping the accelerometer on a hard surface can generate several thousand g of acceleration, potentially exceeding absolute maximum limits and damaging the product.

<sup>(2)</sup> Stainless Steel Casing Grade (e.g. for offshore/marine environment)

<sup>(3)</sup> Aluminium (MIL-A-8625 Type II coating)

## PERFORMANCES – By Model

Range - g	Sensitivity - mV/g	Freq. Response (-3dB) - Hz	Noise - µg/√Hz (Typical)
± 3	900	0 - 500	1.0
± 5	540	0 - 650	1.5

## ELECTRICAL CONNECTIONS – Cable Gland Model

Signal X sensing	Signal Y sensing	Signal Z sensing	4 x 2 x 0,25 <sup>2</sup>
Sensor supply + input	Sensor supply + input	Sensor supply + input	Brown
Sensor supply – input	Sensor supply – input	Sensor supply – input	White
X Axis + Out			Yellow
X Axis - Out			Green
	Y Axis + Out		Pink
	Y Axis - Out		Grey
		Z Axis + Out	Red
		Z Axis - Out	Blue

## ELECTRICAL CONNECTIONS – M12 Connector Model

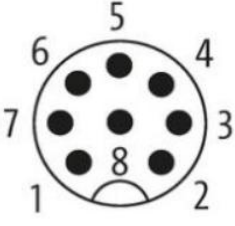
Ud 03		1	+24VDC	Sensor supply + input
		2	OUT Z -	- Voltage differential output
		3	OUT Z +	+ Voltage differential output
		4	OUT Y -	- Voltage differential output
		5	OUT Y +	+ Voltage differential output
		6	OUT X -	- Voltage differential output
		7	OUT X +	+ Voltage differential output
		8	0VDC	Sensor supply - input

## ELECTRICAL CONNECTIONS

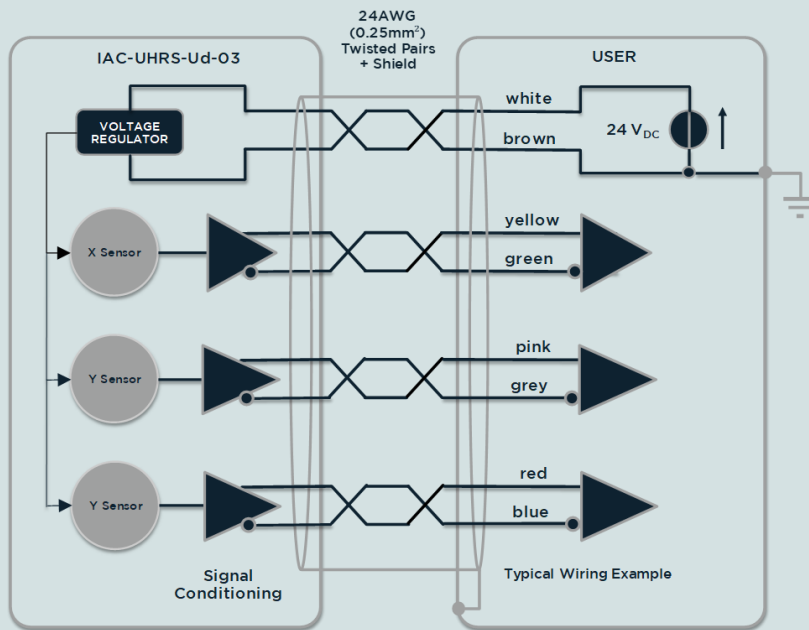

## ORDERING INFORMATION

IAC - UHRS - Ud - 03 - XX - XX - Xg - XX.X m

Cable Connection		Casing		Range	Cable Length
CG	Cable Gland	AL	Aluminium	± 3g	Value in meter
CO	M12	SS	Stainless Steel	± 5g	

Specifications subject to change without notice. – Last updated: April 2026